

FICHA TÉCNICA

VALVULA DE DIAFRAGMA

VALVULA DE DIAFRAGMA PPH

BUEN RENDIMIENTO DE SELLADO EXTERNO

Con análisis 3D CAD / CAE, se instalan válvulas de diafragma con la profundidad de cuerpo adecuada y la profundidad de tornillos adecuada. Además, con caucho de alta elasticidad, el rendimiento de sellado de la válvula.

FÁCIL DE OPERAR

Su facilidad de operar y amplia gama de alternativas, su rendimiento de sellado, forma de material y piezas que la conforman le otorgan una larga vida útil y bajo costo operativo

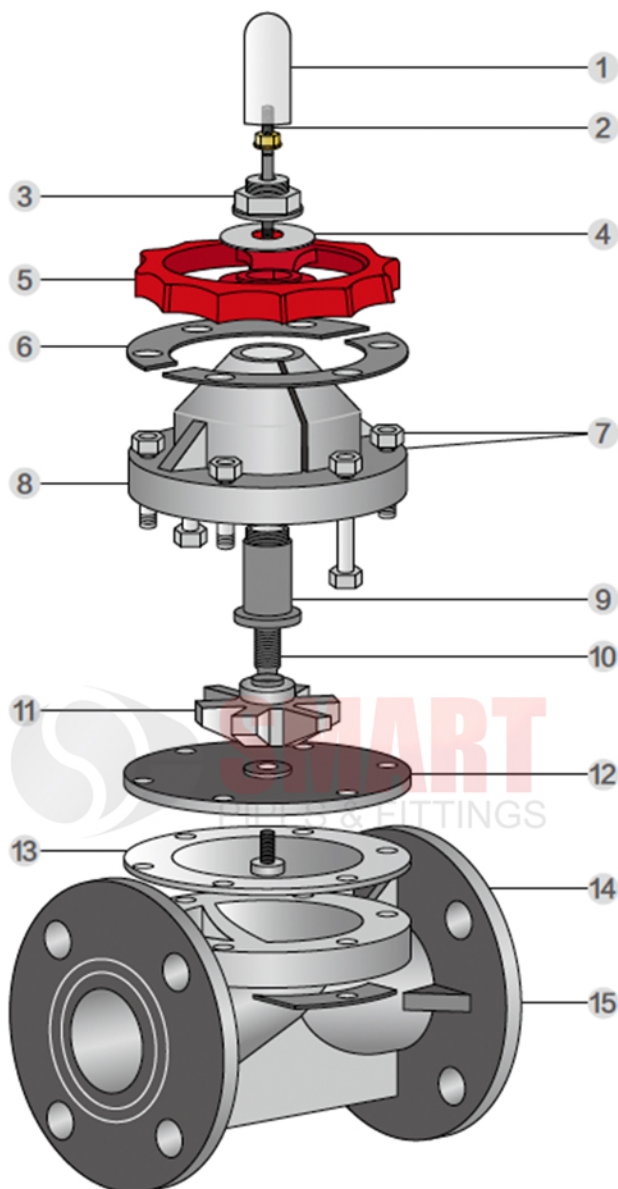

TEMPERATURA DE OPERACIÓN

-14°C +90°C

Nº	NOMBRE	MATERIALIDAD
1	Cubierta protectora	AS
2	Tornillo	Acero
3	Tuerca de retención	FRPP
4	Arandela	FRPP
5	Manilla de Operación	Aleación
6	Pletina	Aceron inox.
7	Tuerca y Espárago	Acero Inox.
8	Cuerpo Superior	PPH
9	Tuerca Yugo	Acero Ht300
10	Vástago	Acero Inox.
11	Disco	PPH
12	Sello Elastomerico	EPDM
13	Diafragma	F46
14	Cuerpo	PPH
15	Conexión Brida	PPH

FICHA TÉCNICA

VALVULA DE DIAFRAGMA

VALVULA DE DIAFRAGMA PPH

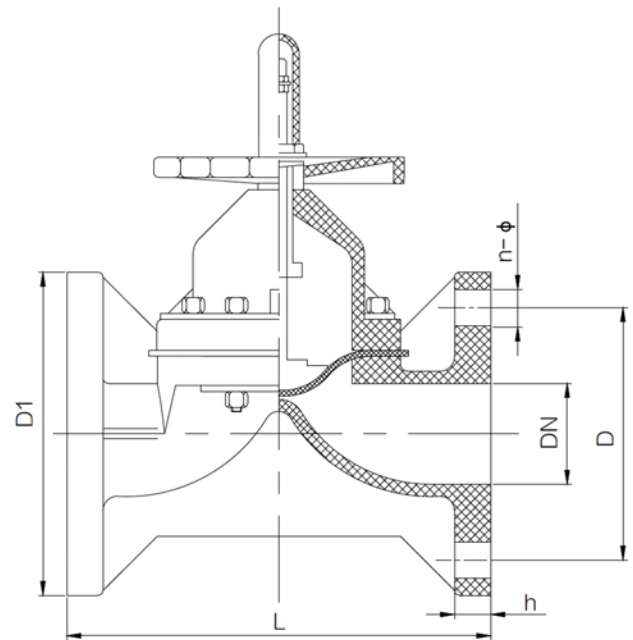

DN (mm)	D1	D				L				h	n				φ			
		D	JIS	DIN	ANSI	L	JIS	DIN	ANSI		n	JIS	DIN	ANSI	φ	JIS	DIN	ANSI
15(1/2")	95	65	70	65	2.38	125	110	130	4.33	14	4	4	4	4	14	15	14	0.63
20 (3/4")	105	75	75	75	2.76	135	120	150	4.72	16	4	4	4	4	14	15	14	0.63
25 (1")	115	85	90	85	3.13	145	130	160	5.12	16	4	4	4	4	14	19	14	0.63
32 (1 1/4")	135	100	100	100	3.45	160				18	4	4	4	4	18	19	18	0.63
40 (1 1/2")	145	110	105	110	3.88	180	180	200	7.09	18	4	4	4	4	18	19	18	0.63
50 (2")	160	125	120	125	4.74	210	210	230	8.27	21	4	4	4	4	18	19	18	0.75
65 (2 1/2")	180	145	140	145	5.49	250	250	290	9.84	22	4	4	4	4	18	19	18	0.75
80 (3")	195	160	150	160	6	300	280	310	11.02	25	8	8	8	8	18	19	18	0.75
100 (4")	215	180	175	180	7.5	350	340	350	13.39	25	8	8	8	8	18	19	18	0.75
125 (5")	245	210	210	210	8.5	400	410	400	16.14	30	8	8	8	8	18	23	18	0.87
150 (6")	280	240	240	240	9.51	455	480	480	18.9	30	8	8	8	8	23	23	23	0.87
200 (8")	335	295	290	295	11.75	570	570	600	22.44	35	8	12	8	8	23	23	23	0.87
250 (10")	390	350	355	350	14.03	680	680	680	26.77	38	12	12	12	12	23	25	23	0.97
300 (12")	445	500	400	400	16.7	680				38	12	16	12	12	23	25	23	0.97